

Pallets and Accessories Specifications



P 11



P 16



P 8



P 13



P 13



P 13



P 17



P 6



P 15



P 2-3



P 4-5



P 7-10

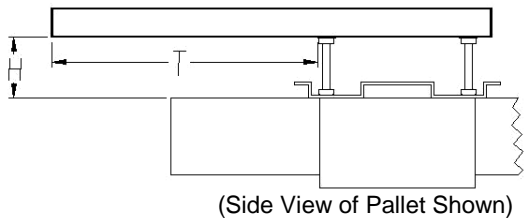
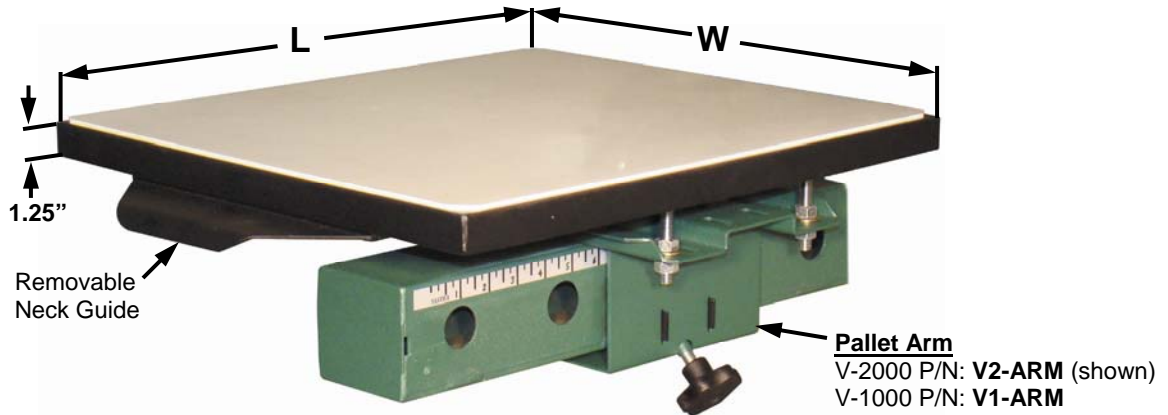

- Features:**
- All steel construction
 - Replaceable rubber top
 - Leveling screws
 - Quick release pallet arm
 - Removable neck guide
 - Call for custom sizes!!

Specifications	10.5" x 17" Junior	12" x 20"	12" x 24"	13" x 8.5"	13" x 11"	13.5 x 17"	14" x 14"
*V-2000 Part Number:	V2P-1017	V2P-1220	V2P-1224	V2P-138	V2P-1311	V2P-1317	V2P-1414
*V-1000 Part Number:	V1P-1017	V1P-1220	V1P-1224	V1P-138	V1P-1311	V1P-1317	V1P-1414
Pallet Rubber Only P/N:	VPR-1017	VPR-1220	VPR-1224	VPR-138	VPR-1311	VPR-1317	VPR-1414
W x L	10.5" x 17" (26.7 x 43.2 cm)	12" x 20" (30.5 x 50.8cm)	12" x 24" (30.5 x 61cm)	13" x 8.5" (33 x 21.6 cm)	13" x 11" (33 x 27.9 cm)	13.5" x 17" (34.3 x 43.2cm)	14" x 14" (35.6 x 35.6cm)
H x T (V-2000)	2" x 10.5" (5.1 x 26.7cm)	2" x 11.5" (5.1 x 29.2 cm)	2" x 15.3" (5.1 x 43.2cm)	2" x 2" (5.1 x 5.1cm)	2" x 5" (5.1 x 12.7 cm)	2" x 10.5" (5 x 26.5" cm)	2" x 7.5" (5 x 19cm)
H x T (V-1000)	1.25" x 10.5" (3.2 x 26.7cm)	1.25" x 11.5" (3.2 x 29.2cm)	1.25" x 15.3" (3.2 x 43.2cm)	1.25" x 2" (3.2 x 5.1cm)	1.25" x 5" (3.2 x 12.7cm)	1.25" x 10.5" (3.2 x 26.5cm)	1.25" x 7.5" (3.2 x 19cm)
Max Image Size:	10" x 16.5" (25 x 39cm)	11.5 x 19.5" (29.2 x 49.5cm)	11.5" x 23.5" (29.2 x 59.7cm)	12.5" x 8" (31.8 x 20.3cm)	12.5" x 10.5" (31.8 x 26.7cm)	13" x 16.5" (33 x 41.9cm)	13.5" x 13.5" (34.3 x 34.3cm)
**Suggested Screen Size:	20" x 24" (51x61cm)	20" x 24" (51x61cm)	20" x 24" (51x61cm)	20" x 24" (51x61cm)	20" x 24" (51x61cm)	20" x 24" (51x61cm)	20" x 24" (51x61cm)
Shipping Weight:	20lb (9.1kg)	21lb (9.5kg)	27lb (12.2kg)	17lb (7.7kg)	18lb (8.2kg)	21lb (9.5kg)	26lb (11.8kg)

For Quick Stretch (Jacket hold-down) specs and availability, please refer to the Quick Stretch spec sheet
 * To order a pallet **without** a Vastex Pallet Arm, add "-NA" after the pallet's part number. Ex: **V2P-1517-NA**
 ** Based on utilizing max image area on pallet. Using smaller screens than indicated will limit max image size.
 *** Requires HD head upgrade for use on V-1000, except when 20" x 24" screens are used and image size is reduced.



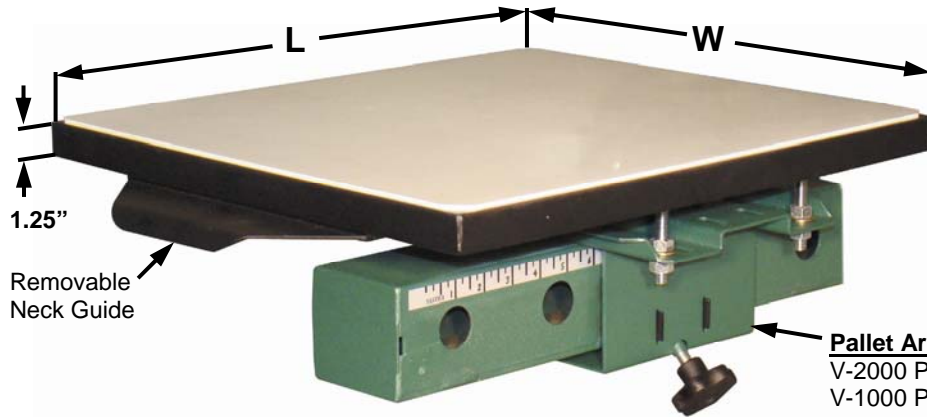

Pallet Arm
 V-2000 P/N: **V2-ARM** (shown)
 V-1000 P/N: **V1-ARM**

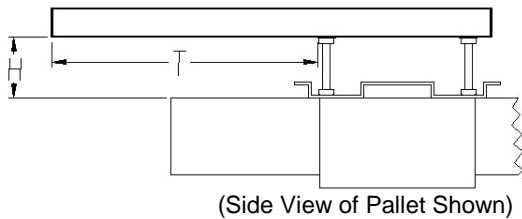

Features:

- All steel construction
- Replaceable rubber top
- Leveling screws
- Quick release pallet arm
- Removable neck guide
- Call for custom sizes!!

<i>Specifications</i>	15" x 17" Standard	16" x 20"	16" x 24"	17" x 21" Oversized	20" x 24" Jumbo
*V-2000 Part Number:	V2P-1517	V2P-1620	V2P-1624	V2P-1721	V2P-2024
*V-1000 Part Number:	V1P-1517	V1P-1620	V1P-1624	V1P-1721***	V1P-2024***
Pallet Rubber Only P/N:	VPR-1517	VPR-1620	VPR-1624	VPR-1721	VPR-2024
W x L	15" x 17" (38.1 x 43.2cm)	16" X 20" (40.6 X 50.8cm)	16" x 24" (40.6 x 61cm)	17" x 21" (43.2 x 53.3cm)	20" x 24" (50.8 x 61cm)
H x T (V-2000)	2" x 10.5" (5.1 x 26.7cm)	2" x 13.5" (5.1 x 34.3cm)	2" x 17" (5.1 x 43.2cm)	2" x 12.25" (5.1 x 31.1cm)	2" x 14" (5.1 x 35.6cm)
H x T (V-1000)	1.25" x 10.5" (3.2 x 26.7cm)	1.25" x 13.5" (3.2 x 34.3cm)	1.25" x 17" (3.2 x 43.2cm)	1.25" x 12.25" (3.2 x 31.1cm)	1.25" x 14" (3.2 x 35.6cm)
Max Image Size:	14.5" x 16.5" (36.8 x 41.9cm)	15.5" x 19.5" (39.4 x 49.5cm)	15.5" x 23.5" (39.4 x 60cm)	16.5" x 20.5" (42 x 52.1cm)	19.5" x 23.5" (49.5 x 60cm)
**Suggested Screen Size:	20" x 24" (51x61cm)	20" x 24" (50.8 x 61cm)	20" x 27.5" (50.8 x 69.9cm)	23" x 31" (58.4 x 78.7cm)	23" x 31" (58.4 x 78.7cm)
Shipping Weight:	23lb (10.4kg)	23lb (10.4kg)	24lb (10.9kg)	27lb (12.2kg)	31lb (14.1kg)

For Quick Stretch (Jacket hold-down) specs and availability, please refer to the Quick Stretch spec sheet

* To order a pallet **without** a Vastex Pallet Arm, add "-NA" after the pallet's part number. Ex: **V2P-1517-NA**

** Based on utilizing max image area on pallet. Using smaller screens than indicated will limit max image size.

*** Requires HD head upgrade for use on V-1000, except when 20" x 24" screens are used and image size is reduced.



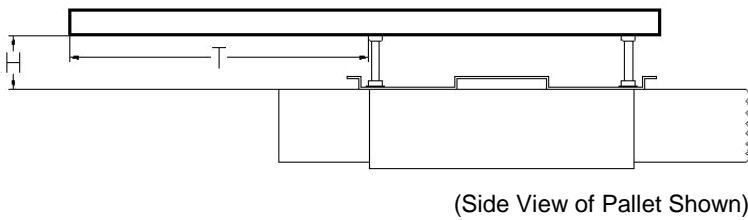

- Features:**
- All steel construction
 - Replaceable rubber top
 - Leveling screws
 - Quick release pallet arm
 - Removable neck guide
 - Call for custom sizes!!

<i>Specifications</i>	12" x 30"	18" x 30"	20" x 30"	22" x 32"	24" x 28"
*V-2000 Part Number:	V2P-1230	V2P-1830	V2P-2030	V2P-2232	V2P-2428
*V-1000 Part Number:	N/A	N/A	N/A	N/A	N/A
Pallet Rubber Only P/N:	VPR-1230	VPR-1830	VPR-2030	VPR-2232	VPR-2428
W x L	12" x 30" (30.5 x 76.2cm)	18" x 30" (45.7 x 76.2cm)	20" x 30" (50.8 x 76.2cm)	22" x 32" (55.9 x 81.3cm)	24" x 28" (61 x 71.1cm)
H x T (V-2000)	1.88" x 18" (4.78 x 45.7cm)	1.88" x 18" (4.78 x 45.7cm)	1.88" x 18" (4.78 x 45.7cm)	1.88" x 21.4" (4.78 x 54.4cm)	1.88" x 16.3" (4.78 x 41.4cm)
H x T (V-1000)	N/A	N/A	N/A	N/A	N/A
Max Image Size:	11.5" x 29.5" (29.2 x 74.9cm)	17.5" x 29.5" (44.5 x 74.9cm)	19.5" x 29.5" (49.5 x 74.9cm)	21.5" x 31.5" (54.6 x 80cm)	23.5" x 27.5" (59.7 x 69.9cm)
**Suggested Screen Size:	25" x 36" (63.5 x 91.4cm)	25" x 36" (63.5 x 91.4cm)	25" x 36" (63.5 x 91.4cm)	25" x 36" (63.5 x 91.4cm)	25" x 36" (63.5 x 91.4cm)
Shipping Weight:	21lb (9.5kg)	32lb (14.5kg)	36lb (16.3kg)	38lb (17.2kg)	34lb (15.4kg)

For Quick Stretch (Jacket hold-down) specs and availability, please refer to the Quick Stretch spec sheet
 * To order a pallet **without** a Vastex Pallet Arm, add "-NA" after the pallet's part number. Ex: **V2P-1517-NA**
 ** Based on utilizing max image area on pallet. Using smaller screens than indicated will limit max image size.
 *** Requires HD head upgrade for use on V-1000, except when 20" x 24" screens are used and image size is reduced.



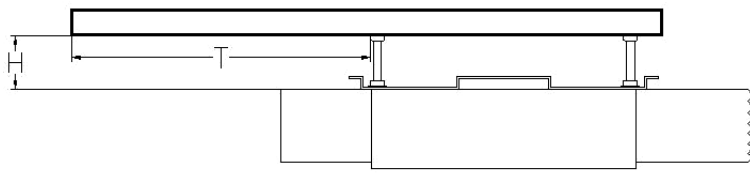

(Side View of Pallet Shown)

Features:

- All steel construction
- Replaceable rubber top
- Leveling screws
- Quick release pallet arm
- Removable neck guide
- Call for custom sizes!!

<i>Specifications</i>	26" x 20"	27" x 32"	48" x 40"
*V-2000 Part Number:	V2P-2620	V2P-2732	V2P-4840
*V-1000 Part Number:	N/A	N/A	N/A
Pallet Rubber Only P/N:	VPR-2620	VPR-2732	VPR-4840
W x L	26" x 20" (66 x 50.8cm)	27" x 32" (68.6 x 81.3cm)	48" x 40" (122 x 102cm)
H x T (V-2000)	1.88" x 8.3" (4.78 x 21.1cm)	1.88" x 21.4" (4.78 x 54.4cm)	1.88" x 26.8" (4.78 x 68.1cm)
H x T (V-1000)	N/A	N/A	N/A
Max Image Size:	25.5" x 19.5" (64.8 x 49.5cm)	26.5" x 31.5" (67.3 x 80cm)	47.5" x 39.5" (120.7 x 100.3cm)
**Suggested Screen Size:	25" x 36" (63.5 x 91.4cm)	25" x 36" (63.5 x 91.4cm)	Custom screen required
Shipping Weight:	38 lb (17.2kg)	41lb (18.6kg)	102lb (46.3kg)

For Quick Stretch (Jacket hold-down) specs and availability, please refer to the Quick Stretch spec sheet

* To order a pallet **without** a Vastex Pallet Arm, add "-NA" after the pallet's part number. Ex: **V2P-1517-NA**

** Based on utilizing max image area on pallet. Using smaller screens than indicated will limit max image size.

*** Requires HD head upgrade for use on V-1000, except when 20" x 24" screens are used and image size is reduced.



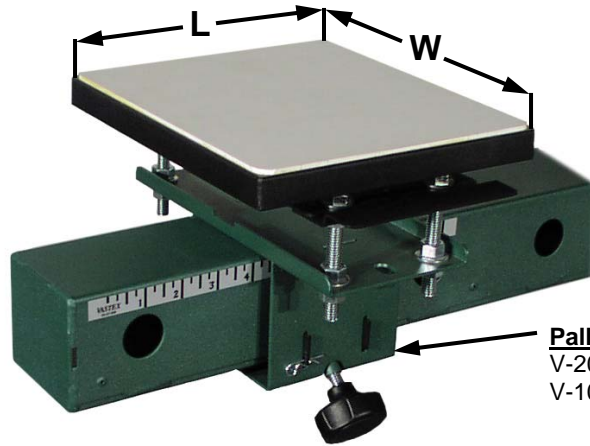

Pallet Arm (Mini)
 V-2000 P/N: **V2-ARM-M** (shown)
 V-1000 P/N: **V1-ARM-M**

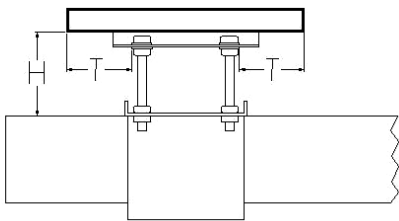

(Side View of Pallet Shown)

- Features:**
- All steel construction
 - Replaceable rubber top
 - Leveling screws
 - Quick release pallet arm
 - Call for custom sizes!!

<i>Specifications</i>	6" x 6" Mini	9" x 8" Mini
*V-2000 Part Number:	V2PM-66	V2PM-98
*V-1000 Part Number:	V1PM-66	V1PM-98
Replacement Rubber P/N:	VPR-66	VPR-98
W x L	6" X 6" (15.25 x 15.25 cm)	9" X 8" (22.9 x 20.3 cm)
H x T (V-2000)	2.9" x 1.2" (7.4 x 3 cm)	2.9" x 2.2" (7.4 x 5.6 cm)
H x T (V-1000)	2.2" x 1.2" (5.6 x 3 cm)	2.2" x 2.2" (3 x 3 cm)
Max Image Size:	5.5" x 5.5" (14 x 14 cm)	8.5" x 7.5" (21.6 x 19.1 cm)
**Suggested Screen Size:	20" x 24" (51x61cm)	20" x 24" (51x61cm)
Shipping Weight:	12lb (5.4kg)	14lb (6.4kg)
Notes:	-Quick Stretch Available and recommended for several applications -Print on Jacket hoods, aprons, bandanas, golf towels, mesh shorts, and many other small materials	-Larger print area than the 6" x 6" -Quick Stretch Available and recommended for several applications -Print on Jacket hoods, aprons, bandanas, golf towels, mesh shorts, and many other small materials

For Quick Stretch (Jacket hold-down) specs and availability, please refer to the Quick Stretch spec sheet

* To order a pallet **without** a Vastex Pallet Arm, add "-NA" after the pallet's part number. Ex: **V2P-1517-NA**

** Based on utilizing max image area on pallet. Using smaller screens than indicated will limit max image size.

*** Requires HD head upgrade for use on V-1000, except when 20" x 24" screens are used and image size is reduced.



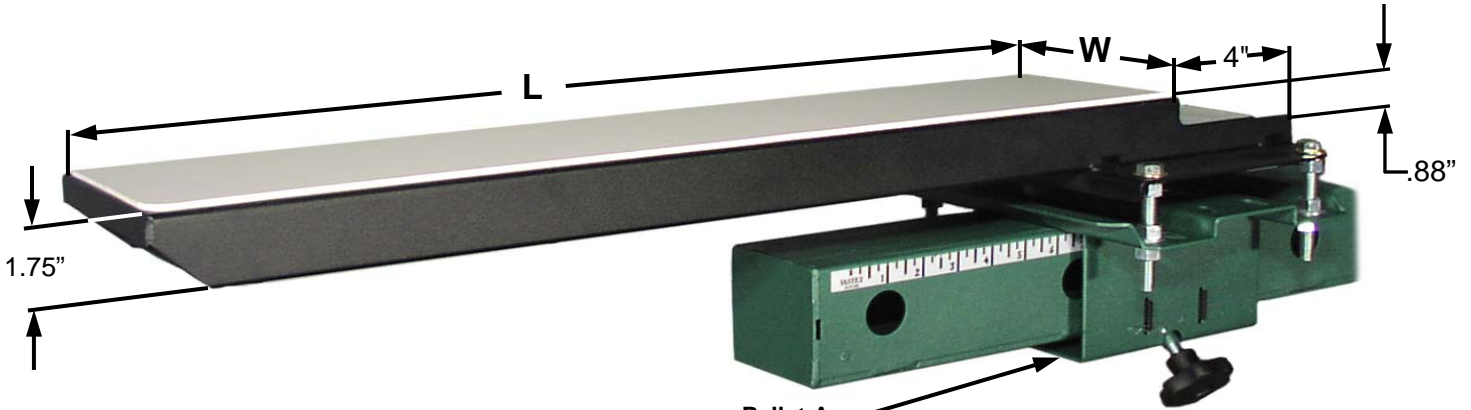

Pallet Arm
 V-2000 P/N: **V2-ARM** (shown)
 V-1000 P/N: **V1-ARM**

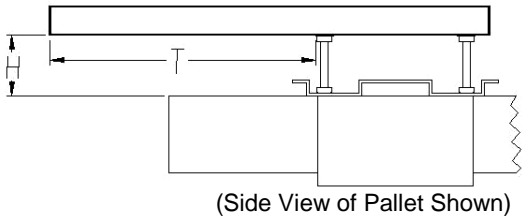

Features:

- All steel construction
- Replaceable rubber top
- Leveling screws
- Quick release pallet arm
- Call for custom sizes!!

<i>Specifications</i>	5" x 24" Leg Pallet	6" x 24" Leg Pallet
*V-2000 Part Number:	V2P-LEG524	V2P-LEG624
*V-1000 Part Number:	V1P-LEG524***	V1P-LEG624***
Replacement Rubber P/N:	VPR-LEG524	VPR-LEG624
W x L	5" x 24" (12.8 x 61cm)	6" x 24" (15.25 x 61cm)
H x T (V-2000)	1.5" x 21.8" (3.8 x 55.3 cm)	1.5" x 21.8" (3.8 x 55.3 cm)
H x T (V-1000)	.8" x 21.8" (2 x 55.3cm)	.8" x 21.8" (2 x 55.3cm)
Max Image Size:	4.5" x 23.5" (11.5 x 60cm)	5.5" x 23.5" (14 x 60cm)
**Suggested Screen Size (V-2000):	23" x 31" (58.4 x 78.7cm)	23" x 31" (58.4 x 78.7cm)
**Suggested Screen Size (V-1000):	V1-46: 23" x 31" (58.4 x 78.7cm) V1-44: Custom, minimum 34" long. (86cm)	V1-46: 23" x 31" (58.4 x 78.7cm) V1-44: Custom, minimum 34" long. (86cm)
Shipping Weight:	13lb (5.9 kg)	14lb (6.4kg)

For Quick Stretch (Jacket hold-down) specs and availability, please refer to the Quick Stretch spec sheet

* To order a pallet **without** a Vastex Pallet Arm, add "-NA" after the pallet's part number. Ex: **V2P-1517-NA**

** Based on utilizing max image area on pallet. Using smaller screens than indicated will limit max image size.

*** Requires HD head upgrade for use on V-1000, except when 20" x 24" screens are used and image size is reduced.



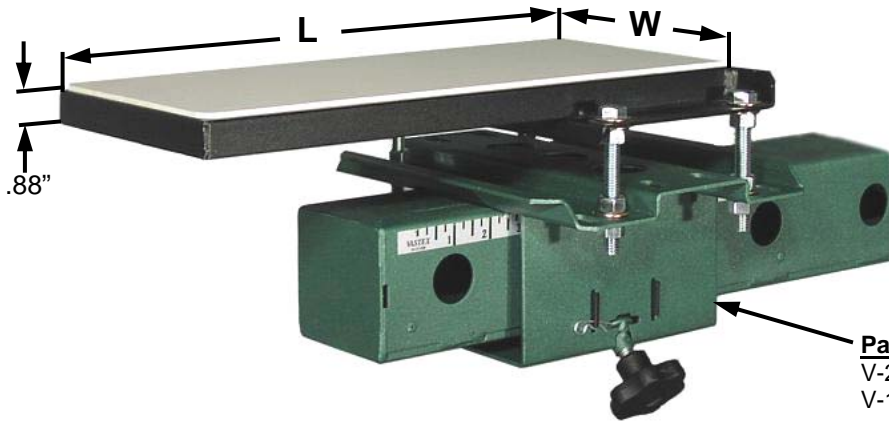

Pallet Arm
 V-2000 P/N: **V2-ARM** (shown)
 V-1000 P/N: **V1-ARM**

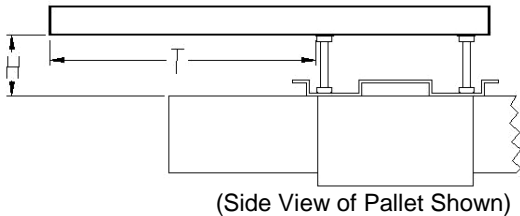

Features:

- All steel construction
- Replaceable rubber top
- Leveling screws
- Quick release pallet arm
- Call for custom sizes!!

With the printing surface extended past the mounting point, these pallets work great for short sleeves, short legs, canvas bags, towels, knit beanies, and many other jobs!

Great for infant and toddler clothing!

<i>Specifications</i>	3" x 9" Short Sleeve	4" x 9" Short Sleeve	5" x 9" Short Sleeve	6" x 9" Short Leg
*V-2000 Part Number:	V2P-SS39	V2P-SS49	V2P-SS59	V2P-LEG69
*V-1000 Part Number:	V1P-SS39	V1P-SS49	V1P-SS59	V1P-LEG69
Replacement Rubber P/N:	VPR-SS39	VPR-SS49	VPR-SS59	VPR-LEG69
W x L	3" X 14" (7.5 X 35.5 cm)	4" x 14" (10 x 35.5cm)	5" x 14" (12.8 x 35.5 cm)	6" x 14" (15 x 35½ cm)
H x T (V-2000)	2.4" X 4.5" (6 X 11½ cm)	2.4" X 4.5" (6 X 11.5 cm)	2.4" X 4.5" (6 X 11.5 cm)	2.4" X 4.5" (6 X 11.5 cm)
H x T (V-1000)	1.6" X 4.5" (4 x 11.5 cm)	1.6" X 4.5" (4 x 11.5 cm)	1.6" X 4.5" (4 x 11.5 cm)	1.6" X 4.5" (4 x 11.5 cm)
Max Image Size:	2.5" x 8.5" (6.3 x 21.5 cm)	3.5" x 8.5" (9 x 21.5 cm)	4.5" x 8.5" (11.5 x 21.5 cm)	5.5" x 8.5" (14 x 21.5 cm)
**Suggested Screen Size:	20" x 24" (51x61cm)	20" x 24" (51x61cm)	20" x 24" (51x61cm)	20" x 24" (51x61cm)
Shipping Weight:	13lb (5.9 kg)	13lb (5.9 kg)	14lb (6.4kg)	14lb (6.4kg)

For Quick Stretch (Jacket hold-down) specs and availability, please refer to the Quick Stretch spec sheet
 * To order a pallet **without** a Vastex Pallet Arm, add "-NA" after the pallet's part number. Ex: **V2P-1517-NA**
 ** Based on utilizing max image area on pallet. Using smaller screens than indicated will limit max image size.
 *** Requires HD head upgrade for use on V-1000, except when 20" x 24" screens are used and image size is reduced.



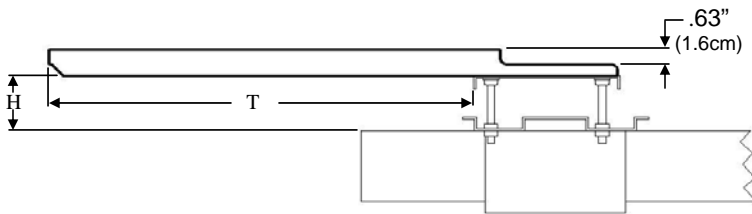
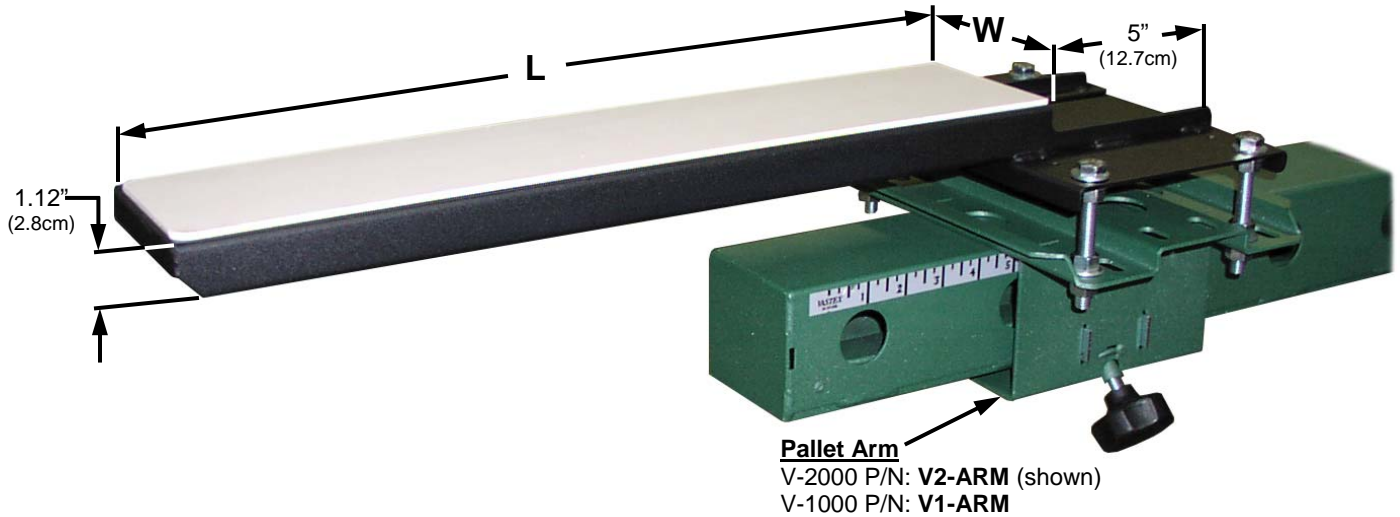

(Side View of Pallet Shown)

Features:

- All steel construction
- Replaceable rubber top
- Leveling screws
- Quick release pallet arm
- Call for custom sizes!!

<i>Specifications</i>	4" x 19" Single Long Sleeve	5" x 19" Single Long Sleeve	6" x 19" Long Sleeve
*V-2000 Part Number:	V2P-SLS419	V2P-SLS519	V2P-SLS619
*V-1000 Part Number:	V1P-SLS419***	V1P-SLS519***	V1P-SLS619***
Replacement Rubber P/N:	VPR-SLS419	VPR-SLS519	VPR-SLS619
W x L	4" x 19.3" (10.2 x 48.9 cm)	5" x 19.3" (12.7 x 48.9cm)	6" X 19.3" (15.2 X 48.9cm)
H x T (V-2000)	2.1" x 18.1" (5.4 x 46 cm)	2.1" x 18.1" (5.4 x 46 cm)	2.1" x 18.1" (5.4 x 46 cm)
H x T (V-1000)	1.4" x 18.1" (3.5 x 46cm)	1.4" x 18.1" (3.5 x 46cm)	1.4" x 18.1" (3.5 x 46cm)
Max Image Size:	3.5" x 18.5" (8.9 x 47 cm)	4.5" x 18.5" (11.4 x 47cm)	5.5" x 18.5" (14 x 47cm)
**Suggested Screen Size: V-2000	23" x 31" (58.4 x 78.7cm)	23" x 31" (58.4 x 78.7cm)	23" x 31" (58.4 x 78.7cm)
**Suggested Screen Size: V-1000	23" x 31" (58.4 x 78.7cm)	23" x 31" (58.4 x 78.7cm)	23" x 31" (58.4 x 78.7cm)
Shipping Weight:	18lb (8.2kg)	19lb (8.6kg)	20lb (9.1kg)

For Quick Stretch (Jacket hold-down) specs and availability, please refer to the Quick Stretch spec sheet

* To order a pallet **without** a Vastex Pallet Arm, add "-NA" after the pallet's part number. Ex: **V2P-1517-NA**

** Based on utilizing max image area on pallet. Using smaller screens than indicated will limit max image size.

*** Requires HD head upgrade for use on V-1000, except when 20" x 24" screens are used and image size is reduced.

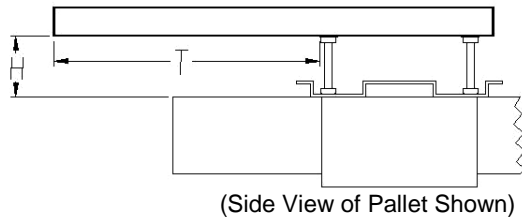
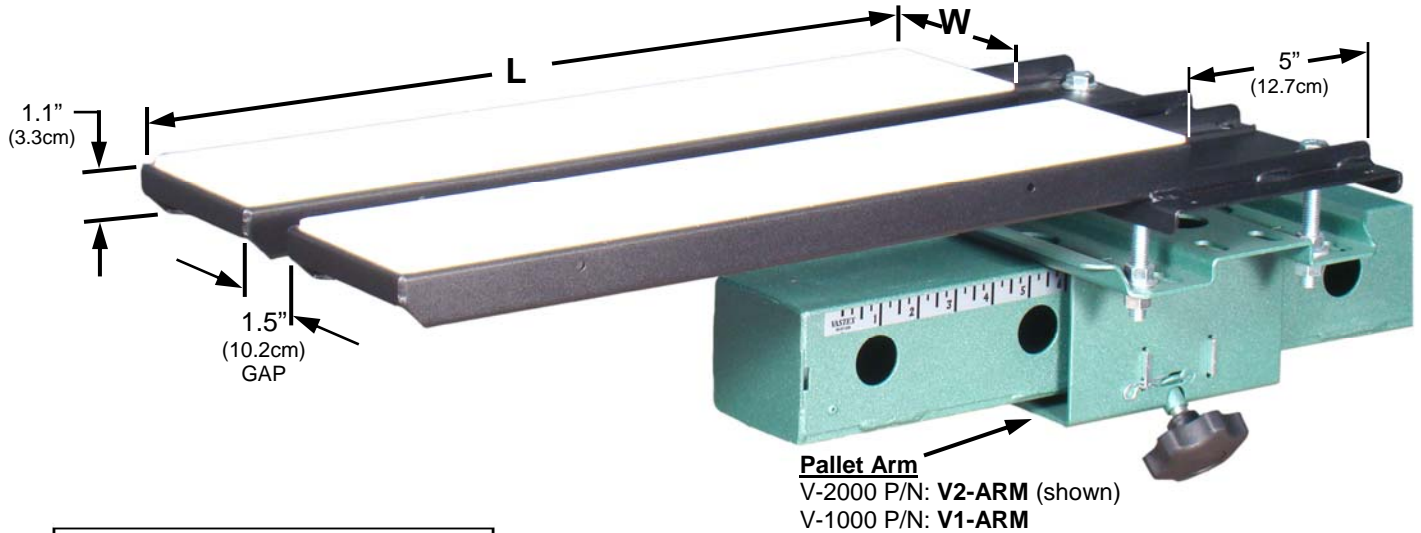

- Features:**
- All steel construction
 - Replaceable rubber top
 - Leveling screws
 - Quick release pallet arm
 - Removable neck guide
 - Call for custom sizes!!

Printing two sleeves with one stroke increases production!!

Specifications	4" x 19" Double Long Sleeve	5" x 19" Double Long Sleeve
*V-2000 Part Number:	V2P-DLS419	V2P-DLS519
*V-1000 Part Number:	V1P-DLS419***	V1P-DLS-519***
Replacement Rubber P/N:	VPR-DLS419	VPR-DLS519
W x L	4" x 24" (10.7 x 61 cm)	5" x 24" (12.7 x 61cm)
H x T (V-2000)	2.2" x 18.8" (4.8 x 47.8 cm)	2.2" x 18.8" (4.8 x 47.8 cm)
H x T (V-1000)	1.5" x 18.8" (2.9 x 47.8 cm)	1.5" x 18.8" (2.9 x 47.8 cm)
Max Image Size:	(2x): 3.5" x 19" (8.9 x 48.3 cm)	4.5" x 19" (11.4 x 48.3cm)
**Suggested Screen Size:	23" x 31" (58.4 x 78.7cm)	23" x 31" (58.4 x 78.7cm)
Shipping Weight:	23lb (10.4kg)	23lb (10.4kg)

For Quick Stretch (Jacket hold-down) specs and availability, please refer to the Quick Stretch spec sheet
 * To order a pallet **without** a Vastex Pallet Arm, add "-NA" after the pallet's part number. Ex: **V2P-1517-NA**
 ** Based on utilizing max image area on pallet. Using smaller screens than indicated will limit max image size.
 *** Requires HD head upgrade for use on V-1000, except when 20" x 24" screens are used and image size is reduced.





Pallet Arm
 V-2000 P/N: **V2-ARM** (shown)
 V-1000 P/N: **V1-ARM**

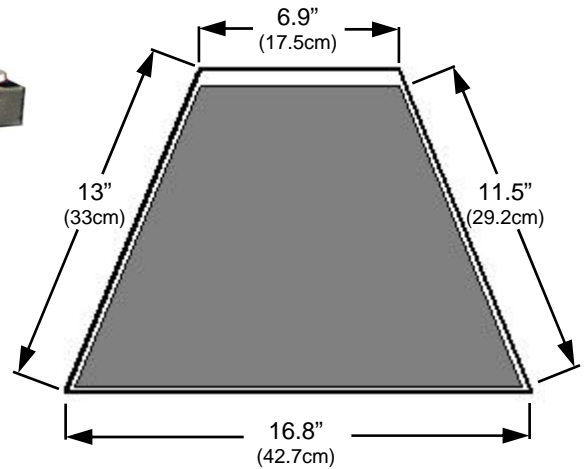

Features:

- All steel construction
- Replaceable rubber top
- Leveling screws
- Quick release pallet arm
- Call for custom sizes!!

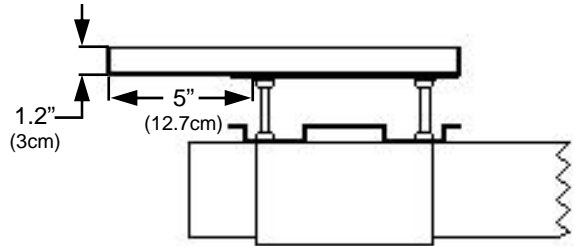

Umbrella pallet shown with optional Quick Stretch (above)

Specifications	Umbrella Pallet	Umbrella Pallet Quick Stretch
*V-2000 Part Number:	V2P-UMB	VQS-UMB
*V-1000 Part Number:	V1P-UMB	VQS-UMB
Replacement Rubber P/N:	VPR-UMB	N/A
Max Image Size:	Varies upon application	Varies upon application
**Suggested Screen Size:	20" x 24" (51x61cm)	20" x 24" (51x61cm)
Shipping Weight:	20lb (9.1kg)	13lb (5.9kg)

For Quick Stretch (Jacket hold-down) specs and availability, please refer to the Quick Stretch spec sheet
 * To order a pallet **without** a Vastex Pallet Arm, add "-NA" after the pallet's part number. Ex: **V2P-1517-NA**
 ** Based on utilizing max image area on pallet. Using smaller screens than indicated will limit max image size.
 *** Requires HD head upgrade for use on V-1000, except when 20" x 24" screens are used and image size is reduced.



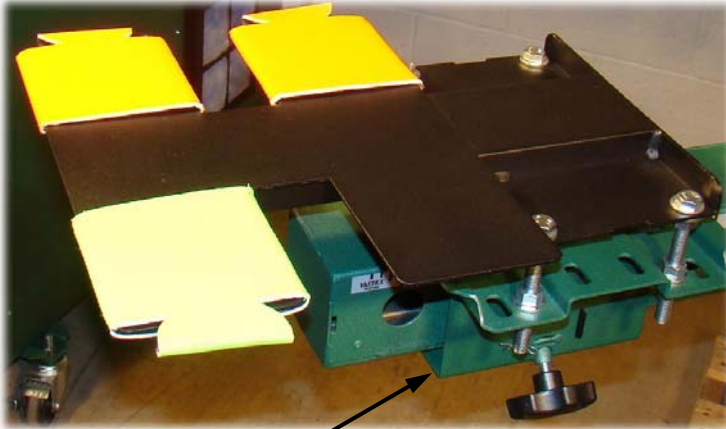

Pallet Arm
 V-2000 P/N: **V2-ARM** (shown)
 V-1000 P/N: **V1-ARM**

Print four koozies at once with this attachment! Simply use the drawing below to locate your artwork to print four simultaneously!!

- Features:**
- All steel construction
 - Leveling screws
 - Quick release pallet arm
 - Call for custom sizes!!

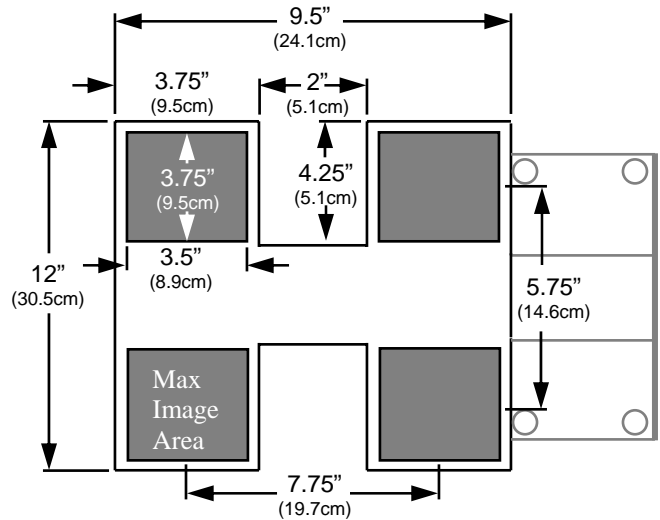

Specifications	Koozie Pallet
*V-2000 Part Number:	V2P-KOOZIE-4UP
*V-1000 Part Number:	V1P-KOOZIE-4UP
Replacement Rubber P/N:	N/A
Max Image Size:	(4x) 3.5" x 3.75" (4x) 8.9 x 9.5cm
**Suggested Screen Size:	20" x 24" (51x61cm)
Shipping Weight:	12lb (5.4kg)
Notes:	-Enables you to print up to 4 flat style koozies at one time.

For Quick Stretch (Jacket hold-down) specs and availability, please refer to the Quick Stretch spec sheet
 * To order a pallet **without** a Vastex Pallet Arm, add "-NA" after the pallet's part number. Ex: **V2P-1517-NA**
 ** Based on utilizing max image area on pallet. Using smaller screens than indicated will limit max image size.
 *** Requires HD head upgrade for use on V-1000, except when 20" x 24" screens are used and image size is reduced.



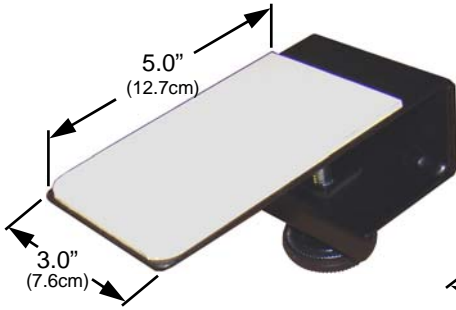

Over Pocket Attachment

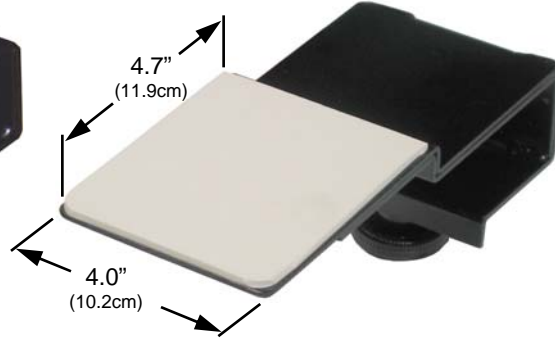

Pocket Attachment

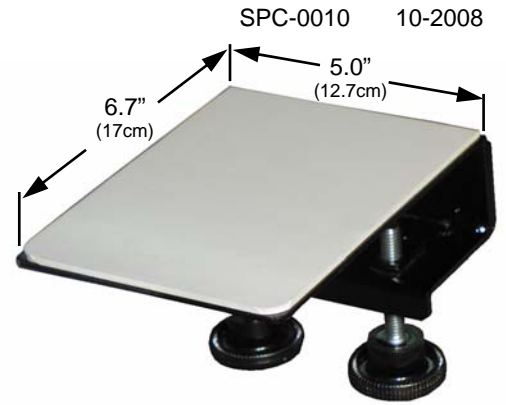

Polo Shirt Attachment

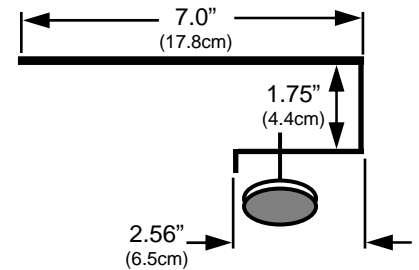
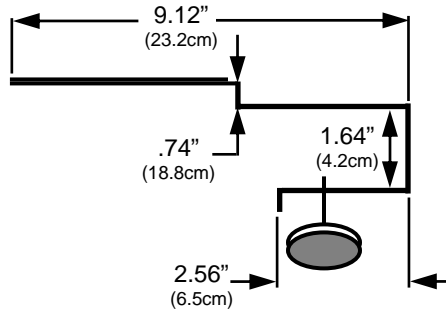
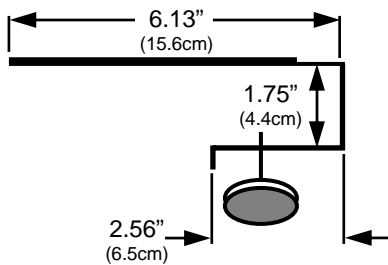
Features:

- All steel construction
- Replaceable rubber top
- Quick release pallet arm
- Call for custom sizes!!

Specifications	Over Pocket Attachment	Pocket Attachment	Polo Attachment
Part Number:	VP-APA	VP-PA	VP-PSA
Replacement Rubber P/N:	VPR-APA	VPR-PA	VPR-PSA
Max Image Size:	2.5" x 4.5" (6.4 x 11.4cm)	3.5" x 4.2" (8.9 x 10.7cm)	4.5" x 6.2" (11.4 x 15.7cm)
**Suggested Screen Size:	20" x 24" (51x61cm)	20" x 24" (51x61cm)	20" x 24" (51x61cm)
Shipping Weight:	3lb (1.4kg)	4lb (1.8kg)	5lb (2.3kg)
Notes:	-Helps simplify alignment of above pocket prints -Brings printing surface above pocket height	-Gives you the ability to print multi-color designs on pockets without the pocket moving -Shim the screen up for quick height adjustment	-Raises printing surface above polo-shirt buttons -Place 2 side by side to print across seams!

For Quick Stretch (Jacket hold-down) specs and availability, please refer to the Quick Stretch spec sheet

* To order a pallet **without** a Vastex Pallet Arm, add "-NA" after the pallet's part number. Ex: **V2P-1517-NA**

** Based on utilizing max image area on pallet. Using smaller screens than indicated will limit max image size.

*** Requires HD head upgrade for use on V-1000, except when 20" x 24" screens are used and image size is reduced.

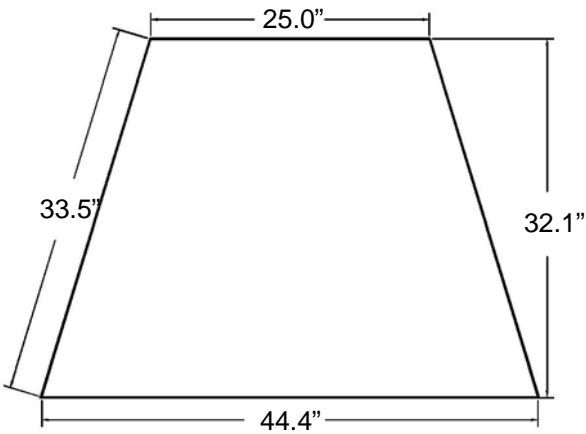

- Features:**
- All steel construction
 - Replaceable rubber top
 - Leveling screws
 - Quick release pallet arm
 - Call for custom sizes!!

See the Videos page on our website to see this pallet in use!
WWW.VASTEX.COM

<i>Specifications</i>	All Over Pallet
*V-2000 Part Number:	V2P-AOP-XLB
*V-1000 Part Number:	N/A
Replacement Rubber P/N:	VPR-AOP-XL
Replacement Foam P/N:	VPF-AOP-XL
Max Image Size:	XL Shirt, All Over
Suggested Screen Size:	Custom to your application
Shipping Weight:	97lb (44kg)

For Quick Stretch (Jacket hold-down) specs and availability, please refer to the Quick Stretch spec sheet
 * To order a pallet **without** a Vastex Pallet Arm, add "-NA" after the pallet's part number. Ex: **V2P-1517-NA**

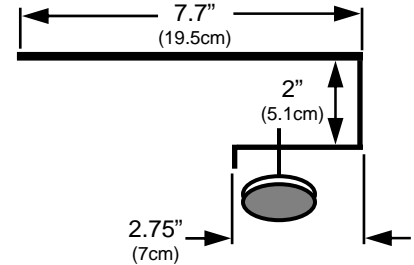
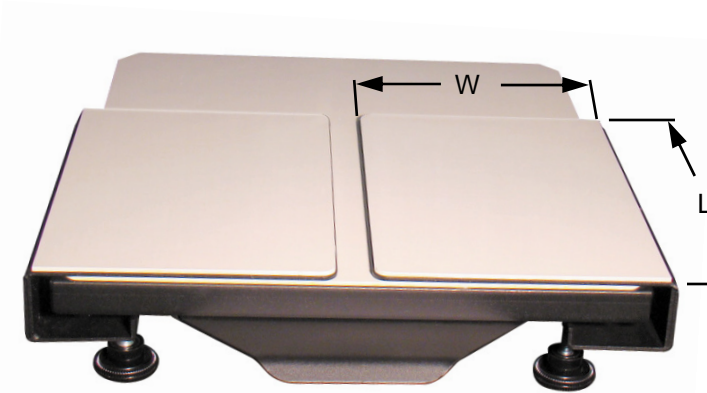

VP-ZAS11 (Pictured) is shown installed as a pair on a 15x17 pallet.

These repositionable attachments accommodate zippers and seams. Position them so a seam lays between them to print right across. Great for zip up hoodies and jackets with seams or panels.	The Zipper attachments are sized, on a 15" wide pallet, to leave as small as a 1/8" gap between the two attachments.
---	--

- Features:**
- All steel construction
 - Replaceable rubber top
 - Quick release pallet arm
 - Call for custom sizes!!

Specifications	Zipper Attachment 11" x 7.5"	Zipper Attachment 16" x 7.5"
Part Number:	VP-ZAS11	VP-ZAS16
Replacement Rubber P/N:	VPR-ZAS11	VPR-ZAS16
L x W	11" x 7.5"	16" x 7.5"
Max Image Size (Using two attachments):	10" x 14" (25.4 x 35.6cm)	15" x 14" (38 x 35.6cm)
**Suggested Screen Size:	20" x 24" (51x61cm)	20" x 24" (51x61cm)
Shipping Weight:	20lb (9.1kg)	20lb (9.1kg)

For Quick Stretch (Jacket hold-down) specs and availability, please refer to the Quick Stretch spec sheet
 * To order a pallet **without** a Vastex Pallet Arm, add "-NA" after the pallet's part number. Ex: **V2P-1517-NA**
 ** Based on utilizing max image area on pallet. Using smaller screens than indicated will limit max image size.
 *** Requires HD head upgrade for use on V-1000, except when 20" x 24" screens are used and image size is reduced.



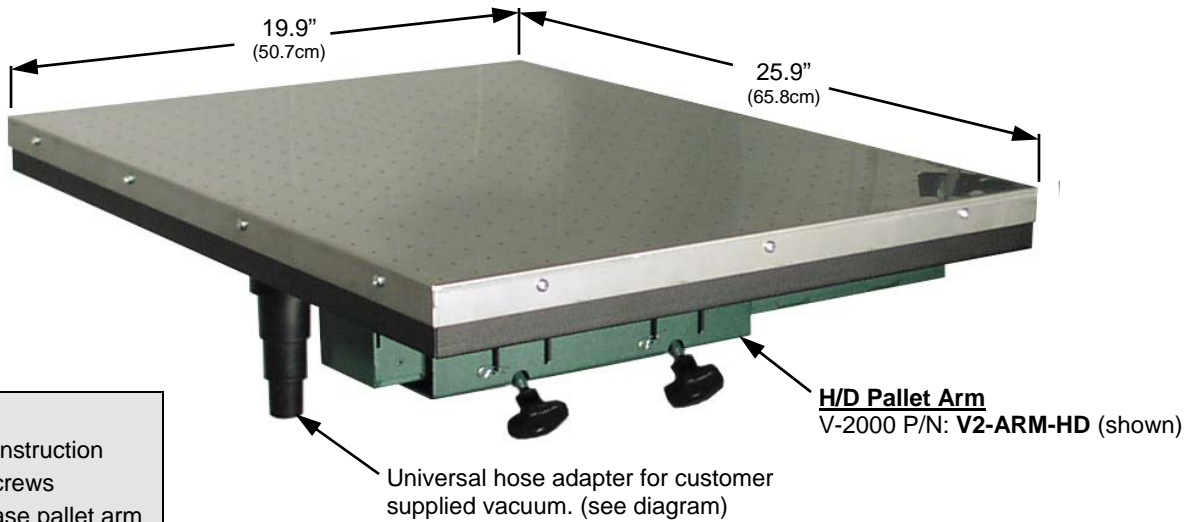

Features:

- All steel construction
- Leveling screws
- Quick release pallet arm
- Call for custom sizes!!

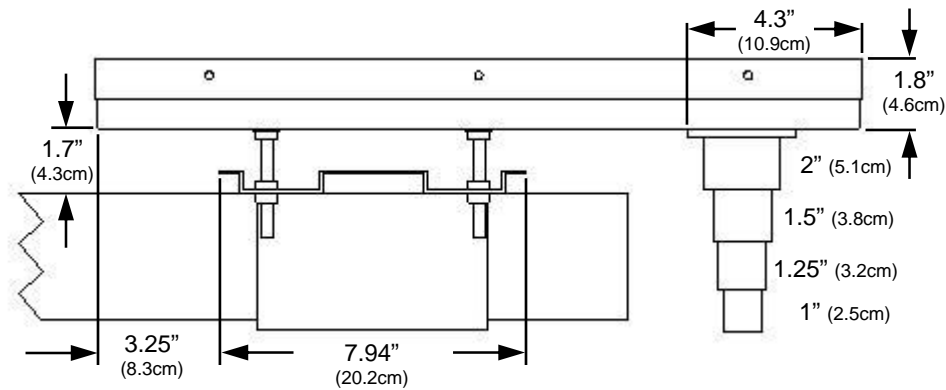

Specifications	Vacuum Pallet
*V-2000 Part Number:	V2-VT-1824
*V-1000 Part Number:	N/A
Replacement Rubber P/N:	N/A
Max Image Size:	18" x 24" (45.7 x 61cm)
**Suggested Screen Size:	23" x 31" (58.4 x 78.7cm)
Shipping Weight:	20lb (9.1kg)
Notes:	-Great for printing chloroplast signs, heat transfers, paper, thin plastic, and more! -Enables you to print on materials unable to be held by glue or quick stretch

For Quick Stretch (Jacket hold-down) specs and availability, please refer to the Quick Stretch spec sheet

* To order a pallet **without** a Vastex Pallet Arm, add "-NA" after the pallet's part number. Ex: **V2P-1517-NA**

** Based on utilizing max image area on pallet. Using smaller screens than indicated will limit max image size.

*** Requires HD head upgrade for use on V-1000, except when 20" x 24" screens are used and image size is reduced.



Rubber on three sides on
10.5" x 17" and larger

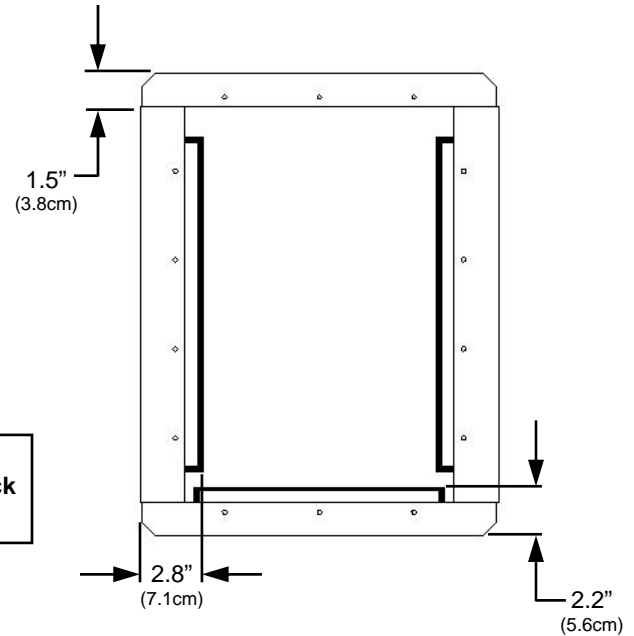
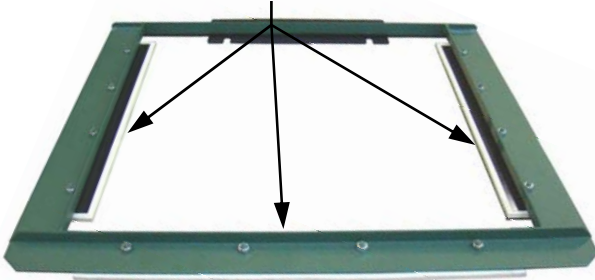

- Adjustable rubber to accommodate different materials!
- Use a Vastex Quick Stretch for printing without spray tack
- Great for 2-ply materials like jackets!

- Features:**
- All steel construction
 - Call for custom sizes!!

Specifications	6" x 6"	4" x 17" Sleeve	9" x 8"	13" x 11"	10.5" x 17" Junior	15" x 17" Standard	17" x 21" Oversize	Umbrella
*V-2000 Part Number:	VQS-66	VQS-417	VQS-98	VQS-1311	VQS-1017	VQS-1517	VQS-1721	VQS-UMB
Shipping Weight:	9lb (4.1kg)	13lb (5.9kg)	10lb (4.5kg)	11lb (5kg)	13lb (5.9kg)	16lb (7.3kg)	20lb (9.1kg)	14lb (6.4kg)
Number of hold down, rubber sides:	4	4	4	3	3	3	3	3
Notes:		-Includes cap to fit over pallet						





Specifications	Cap Package Base
V-2000 Part Number:	V2C-CPB
V-1000 Part Number:	V1C-CPB
Cap Package Screen Holder for V-1000 and V-2000	VC-CPS (includes Squeegee)
Shipping Weight:	16Lbs (7.3kg)

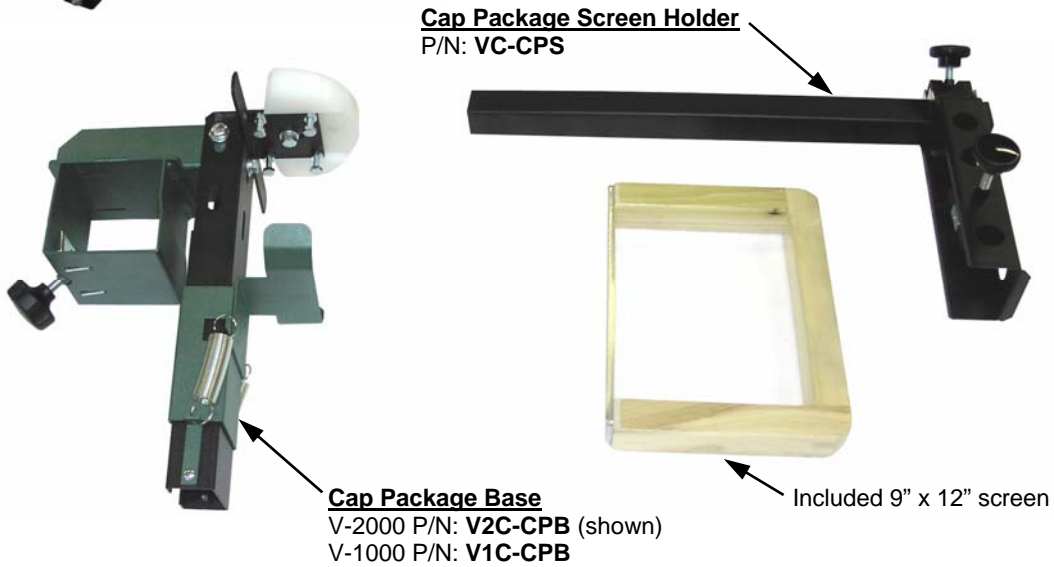

Pallet Options

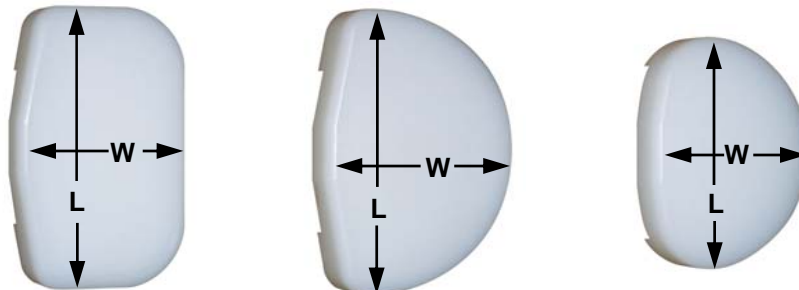

Pallet Options	Style 1	Style 2	Style 3
Part Number:	VP-H1	VP-H2	VP-H3
Length x Width (L x W):	5.13" x 3" (13 x 7.6cm)	4.88" x 3" (12.4 x 7.6cm)	3.56" x 2.5" (9 x 6.4cm)

Stop getting ink all over your screen when doing pocket images!

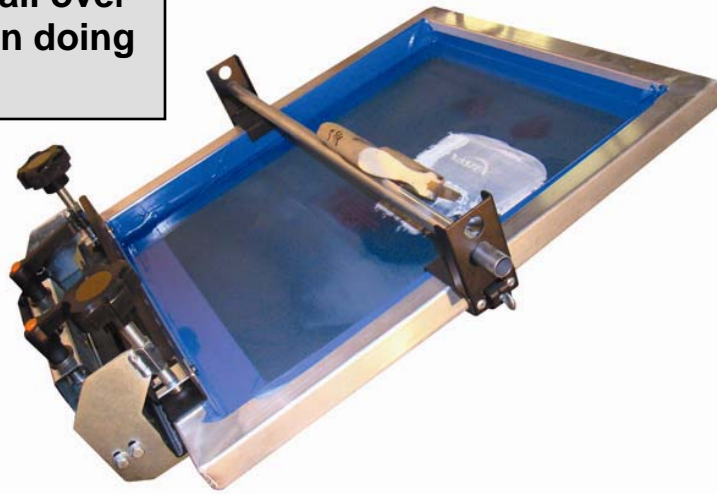

Great for any application! Will fit on any screen, round or square framed, with a diameter or width of 2" or less.

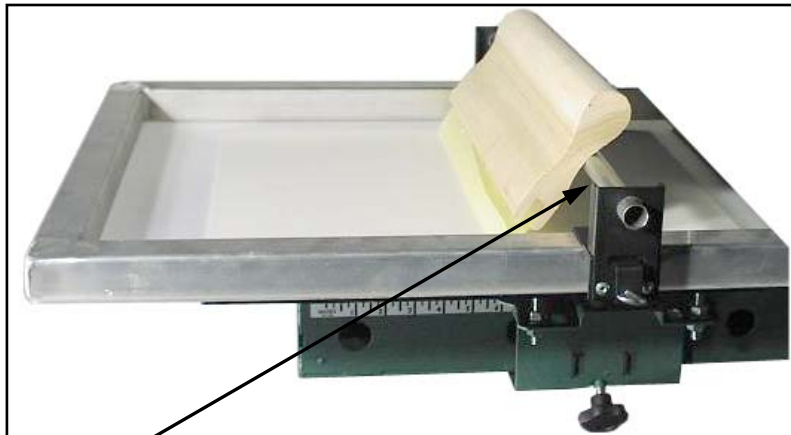

Squeegee Rest
P/N: VN-WT2
-Includes 2 Clamp Assemblies

Support tube **(customer supplied)**
-5/8" dia. wood dowel or
1/2" emt conduit
-Cut 1" longer than width of screen

To use with round tube framed screens, you must attach friction tape to the clamping surfaces.

Specifications	Squeegee Rest
Part Number:	VN-WT2
Screen Rail Width:	Will work with up to 2" screen rails, square or round. Will NOT work on Newman Roller M3's
Shipping Weight (one set):	1lb (.45kg)



SC-2230/SC-2630



SC-2230: Clamp-on side clamps

SC-2212/SC-2612



SC-2212: Clamp-on side clamps

SC-22/SC-26



SC-26: Clamp-on side clamps

Side clamps are available in two widths, 22" & 26". Fixed side clamps, shown above, are available to V-2000 owners. All rear clamp presses can use the clamp-on side clamps.

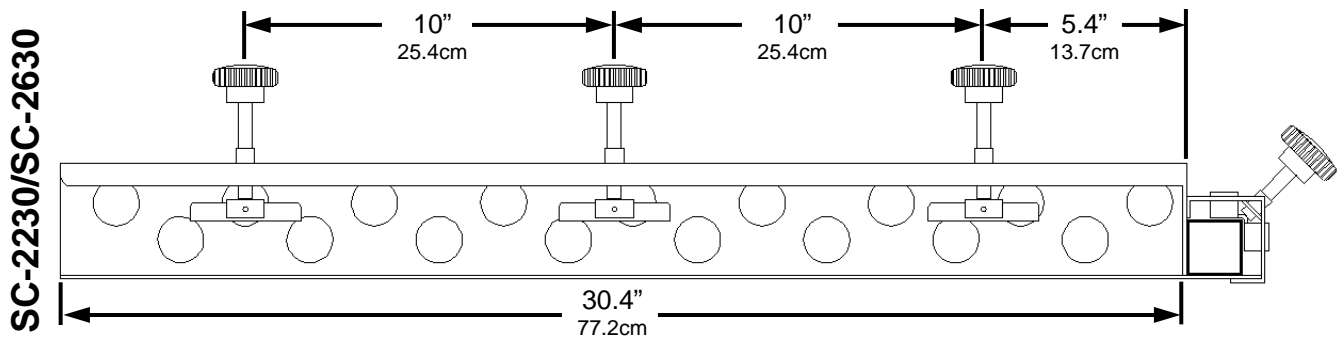
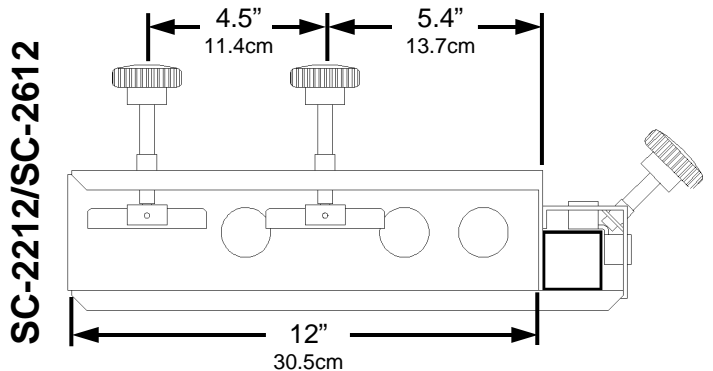
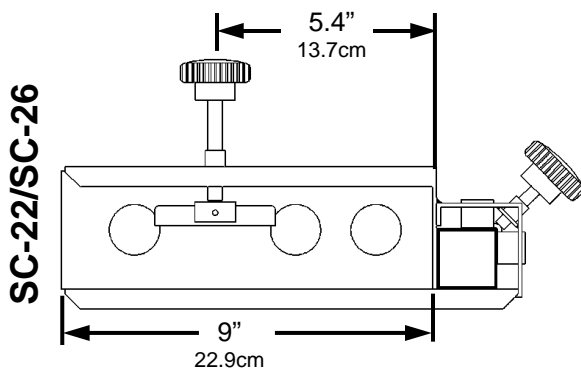

Specifications	SC-22	SC-26	SC-2212	SC-2612	SC-2230	SC-2630
Max Screen Width:	22" (55.9cm)	26" (66cm)	22" (55.9cm)	26" (66cm)	22" (55.9cm)	26" (66cm)
Attachment weight:	8.5lb (3.9kg)	8.5lb (3.9kg)	10.5lb (4.8kg)	10.5lb (4.8kg)	16lb (7.3kg)	16lb (7.3kg)
Shipping Weight:	10.5lb (4.8kg)	10.5lb (4.8kg)	12.5lb (5.7kg)	12.5lb (5.7kg)	18lb (8.2kg)	18lb (8.2kg)

Works on almost any rear clamp press!!

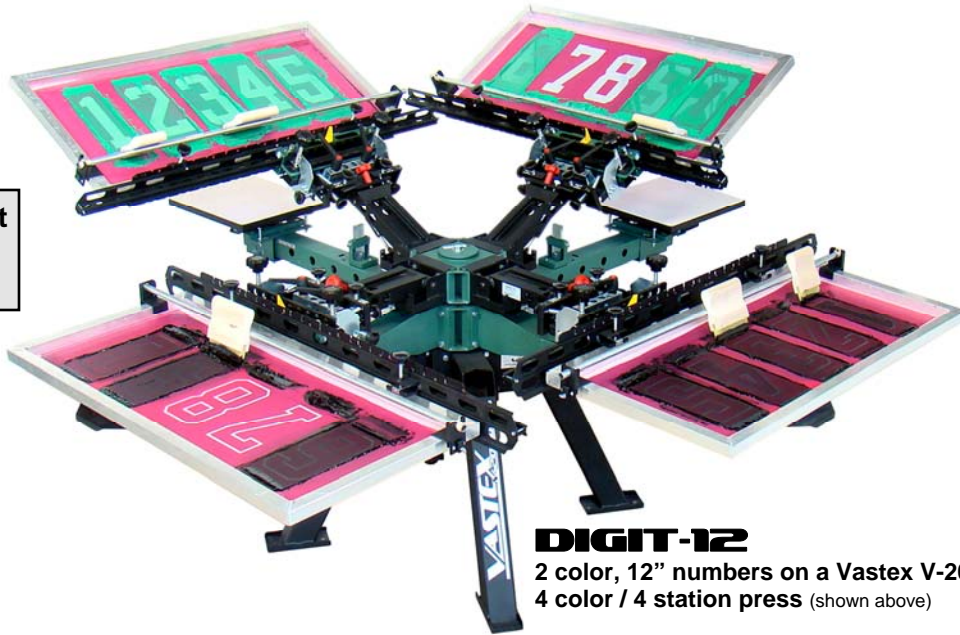

DiGiT-12
2 color, 12" numbers on a Vastex V-2000
4 color / 4 station press (shown above)

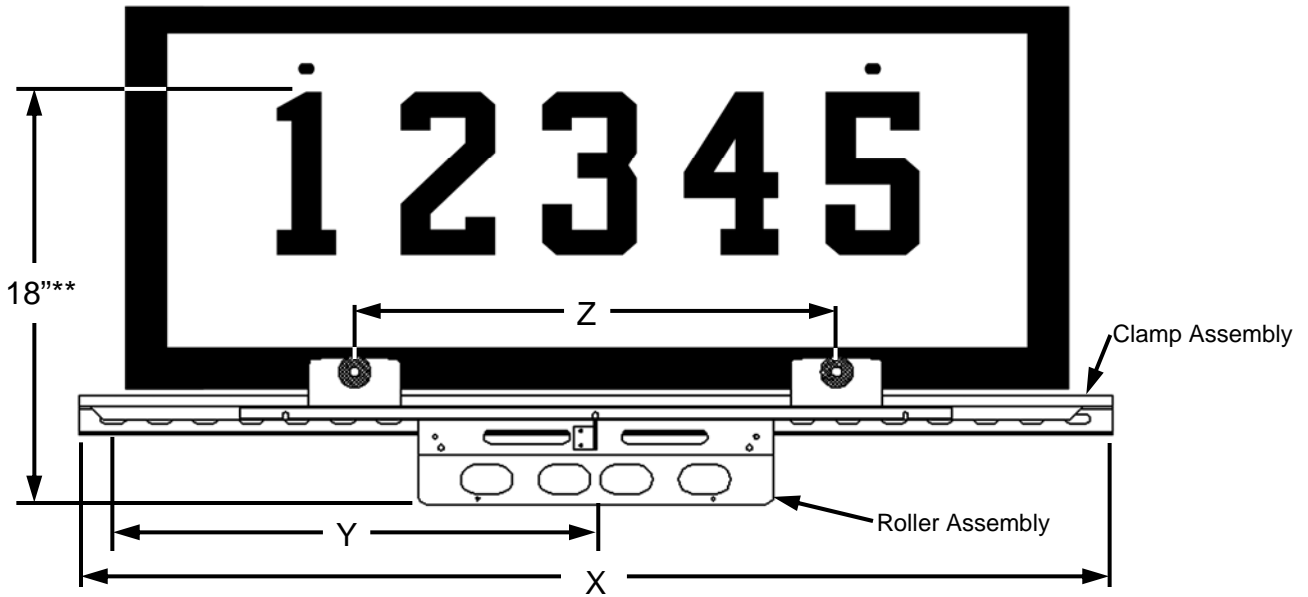

**This dimension of 18" is critical when determining how the DiGiT system will work on your press. From the top edge of the number, to the back of your screen clamps is 18". Your pallet must be able to move to this position. 19" is the recommended minimum for this dimension.

Specifications	DiGiT-8	DiGiT-12
Standard number size capability	4", 6", & 8"	4", 6", 8", 10", 12"
X: Length of Screen Holder	45" (114.3cm)	56" (142.2cm)
Y: Amount of movement from center point	14.5" (36.8cm)	19" (48.3cm)
Z: Distance between screen clamps	21" (53.3cm)	27" (68.6cm)
Weight of each attachment with screen	26 lbs	29 lbs
Shipping Weight and Dimensions	(2x) 48" x 9" x 9" @ 28lbs (122 x 23 x 23cm @ 12.7kg)	(2x) 59" x 9" x 9" @ 33lbs (150 x 23 x 23cm @ 15kg)

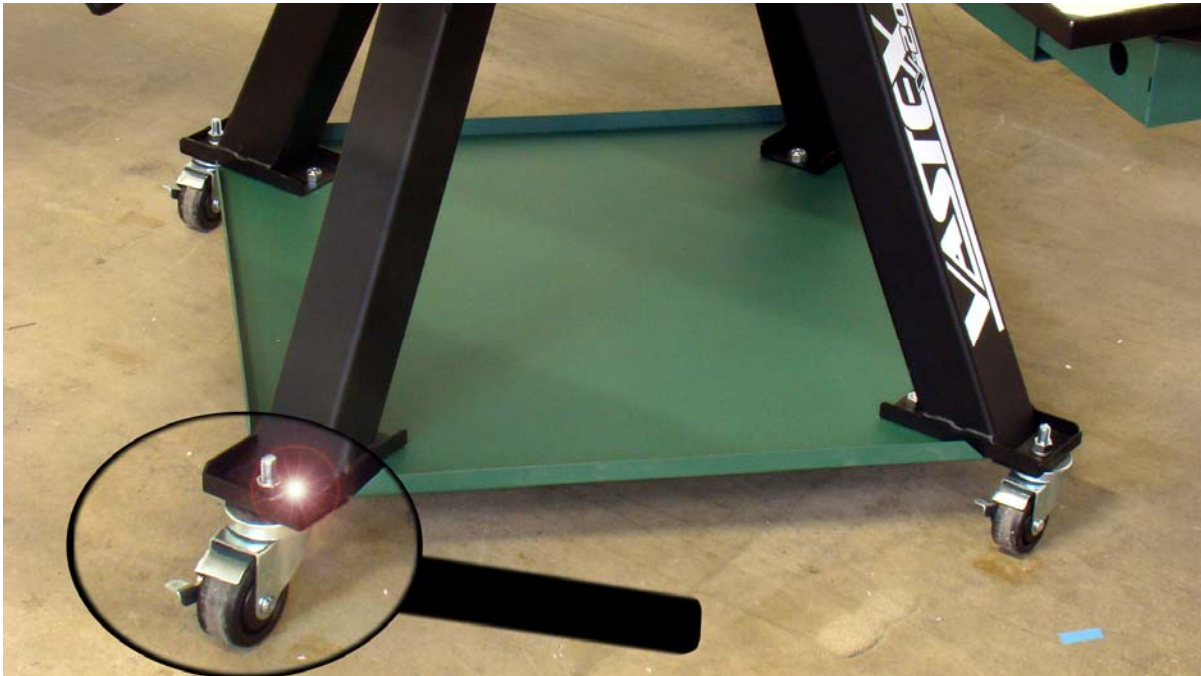

V-2000 Service Pan and Wheels (shown above) raise machine height 4.25".
Wheels are available without Service Pan.



V-1000 Service Pan and Wheels (shown above) raise machine height 4.25".
Wheels are **not** available without Service Pan.

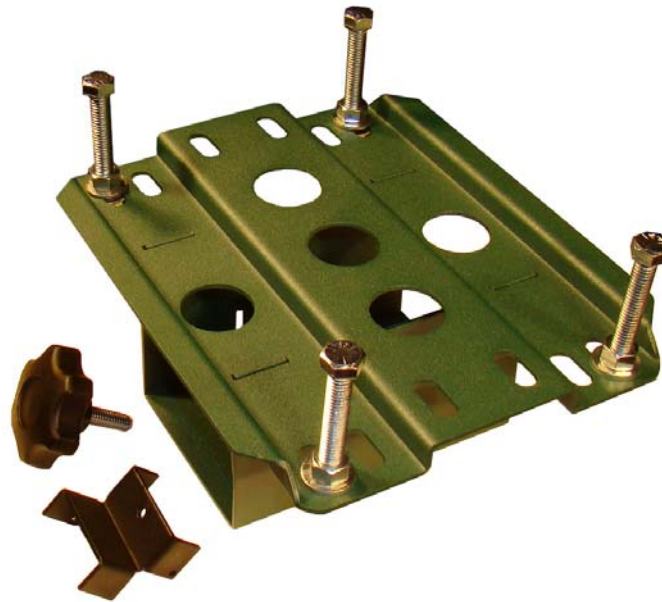

Pallet arms are available separately for V-2000 and V-1000 model printers. Pallet arms can be purchased to enable you to make custom pallets out of any material you desire and in any shape you need.

V-2000 has 3 different size Pallet Arms available

- Mini Pallet arm– For use with small custom pallets up to 9” square.
- Standard Pallet arm (shown above)– For use with pallets up to 24” in length.
- HD Pallet arm– For use with all over-sized pallets.

V-1000 has 2 different size Pallet Arms available

- Mini Pallet arm– For use with small custom pallets up to 9” square.
- Standard Pallet arm– For use with custom pallets up to 24” in length

Vastex International Inc.
610.434.6004 | Toll Free 800.482.7839 | Fax 610.434.6607 | www.vastex.com

